

CAUTION

- (1) Applying a voltage or current exceeding its maximum permissible value may cause the unit to be damaged.
- (2) Always use the unit within the specified voltage range: otherwise, it may cause a fire, electric shock or personal/equipment damage.
- (3) For the purpose of functional improvement, the information written herein may be changed without prior notice.
- (4) Information contained herein is considered accurate to the best of our knowledge. If you have any question or comment on the information, please contact us or our distributor.
- (5) Read this manual carefully and thoroughly before starting to operate the unit, and keep the manual available for future reference.

1. Before Using the Unit

Thank you for purchasing our A8000 Series Digital Panelmeter. Please make sure that the operator who uses the panelmeter keeps the manual on hand. Also, the meter should be checked upon receipt for damage that might have occurred while in transit. Should the product be damaged or any accessory be missing, notify your sales representative or our sales office directly.

1.1 Model and Suffix Code Configuration

The model and suffix code of the A8000 series are as shown below. Check that the product received matches the one you selected when ordering.

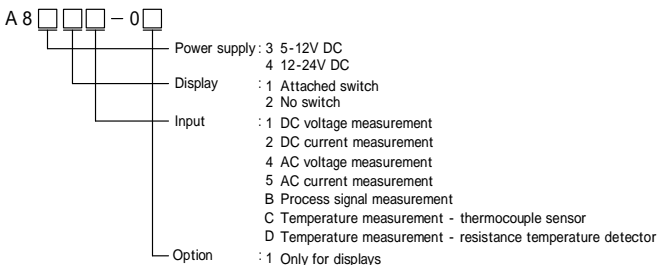

* In case of No switch display option, parameters are set to specified values upon request.
[CAUTION]: This machine become it if there are neither BCD output nor External control when selecting it only for the display.

1.2 Checking the Accessories

The A8000 series accessories include one copy of this Operation Manual and one unit label.

*when BCD is selected by the option,BCD connector(Card edge type 26P)is attached.

2. Mounting Method

2.1 Panel Cutout Size

Panel cutout for mounting the A8000 series digital panelmeter is as shown below:

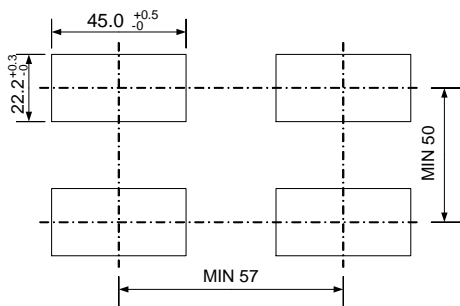

* Recommended panel thickness: 1 to 8 mm

2.2 External Dimensions

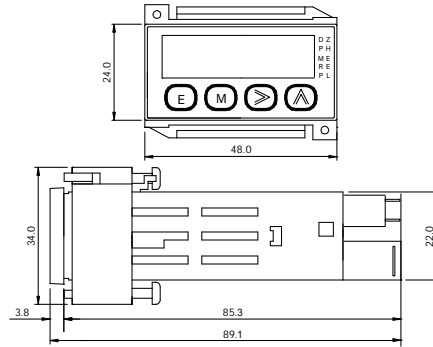

* In case of No switch display option, there is not print on the front panel.

2.3 How to Mount the Unit on the Panel

With the mounting bands detached from the main unit, insert the main unit into the opening in a panel from the front of the panel, and then attach the mounting bands to the main unit from the rear of the panel for fixing.

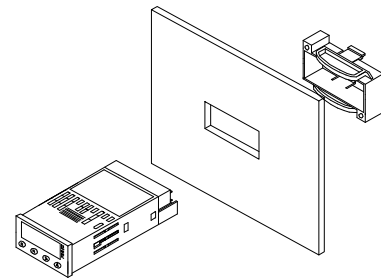

CAUTION

- (1) Do not install the unit where it is exposed to dust, particles, chemicals harmful to electric components, corrosive gases, etc.
- (2) When this unit is installed inside other equipment, pay attention to the heat radiation and keep the heat inside the equipment 50°C or below.
- (3) Exercise care so that the product is not subject to vibrations or shocks.

3. Terminals and Connections

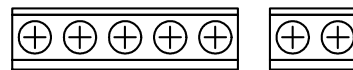
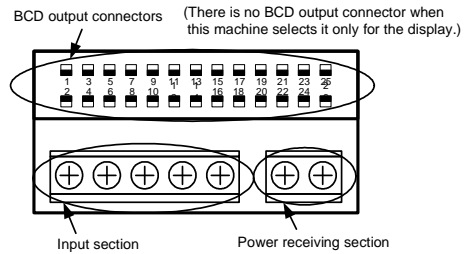

Lower terminals

- ①: Input terminal HI (+ input terminal of 1V-range)
- ②: Input terminal HI (+ input terminal of 2A-range)
- ③: Input terminal LO (- input terminal)
 - Make input signal wires as short as possible and keep them away from other signal wires.
 - Use two-core shielded cables in locations with a lot of external noise and connect the external sheaths to the LO side of the signal source at one point.
 - If harmonic noise is superimposed on an input signal, use a low-pass filter at the time of input. However, care must be exercised depending on the usage conditions because a delay in response time is caused in time constant.
- ④, ⑤: NC terminals
 - Do not connect anything to the NC terminals.
- ⑥: Power terminal (DC POWER 0 V)
- ⑦: Power terminal (DC POWER +V)
 - The A8000 series panelmeter has no power switch; connecting it to a power source causes it to be operable immediately.

Upper terminals (only for units with BCD outputs)

This machine become it if there are neither BCD output nor External control when selecting it only for the display.

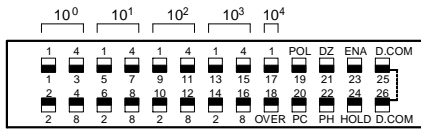

Caution

- The BCD output logic can be switched using the BCD logic parameter (BCD.L) of the condition data, which is positive when BCD.L is set to P.LOG and negative when BCD.L is set to N.LOG for an output type of Open collector. This logic is reversed if the output type is "TTL."
- The lock function is not provided in the BCD connector, and use it, please with the load doesn't hang to the connector.

- 1 to 17: Outputs of bits 1, 2, 4, and 8 of each digit
- 18: BCD overrange output
- 19: BCD polarity output
- 20: BCD printout command output
- 21: Digital Zero
 - Shorting this terminal and D.COM terminal or bringing their potential to the "0" level allows the meter to perform measurements with the previously displayed value as "zero." This feature displays the width of variations from that point onward.
- 22: Peak Hold
 - Shorting this terminal and D.COM terminal or bringing their potential to the "0" level allows the meter to display and hold the maximum value (Peak Hold), minimum value (Valley Hold), or the difference between the maximum and minimum values (Peak - Valley Hold). These functions can be switched using condition data.
- 23: BCD Enable
 - Shorting this terminal and D.COM terminal or bringing their potential to the "0" level causes BCD output to be high impedance or the transistor to be turned OFF.
- 24: Hold
 - Shorting this terminal and D.COM terminal or bringing their potential to the "0" level causes the panelmeter to maintain its indication.
- 25, 26: D.COM
 - Common terminals for BCD outputs and control terminals
 - "0" level: 0 to 1.5 V, "1" level: 3.5 to 5 V, and input current: -0.5 mA

4. Parameter Settings

4.1 Components and Functions

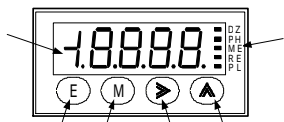

- ① Main display unit: Displays a measured value or a menu or parameter information during parameter setup.
- ② Function monitoring indicator: Lights up when the control function is being used or blinks when a variety of settings is made.
- ③ Enter switch: Shifts the panelmeter from measurement status to parameter setting status (Enter + Mode).
- ④ Mode switch: Shifts to the item you wish to change during parameter setting. Shifts to a shift data setting status (Mode + Shift) Digital zero ON/OFF control on the front panel (Mode + Increment)
- ⑤ Shift switch: Moves to the digit where you wish to carry out setup during parameter setting. Shifts to a shift data setting status (Mode + Shift)
- ⑥ Increment switch: Allows you to choose a numeric value during parameter setting (Increment) or select information. Digital zero ON/OFF control on the front panel (Mode + Increment)

* If condition data "b.up" is Off, disconnecting the power supply causes a digital zero value to be cleared. In case of No switch display option, there is not print on the front panel but the switches are implemented.

4.2 Numeric and Character Indications



4.3 Parameter Types and Protect Levels

The 43DV2 series parameters are classified into the following groups depending on the main objective. Use of the protect setting in the condition data allows a limitation to be imposed on the settable parameters.

- Condition data: A group of parameters that set up basic actions such as the sampling rate and operation type for each control.
- Scaling data: A group of parameters relating to measurements such as scaling.
- Linearize data: A group of parameters relating to the function of correcting the linearity of an input value and display value.

4.4 Shift to the Parameter Setting Mode

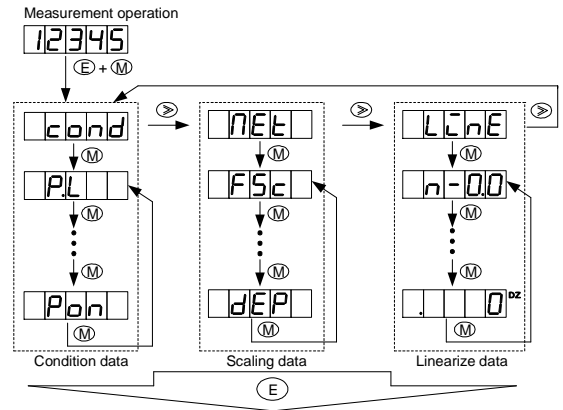

When the Enter key is pressed, the panelmeter stores data and returns to measurement operation.

4.5 Protect Levels

- Protect level 0 (PL0): Allows all parameters to be displayed (set).
- Protect level 1 (PL1): Allows condition and scaling data to be displayed (set). Note: Condition data display (setting) is available only for protection, range, and the number of averaging (sampling) times.
- Protect level 2 or 3 (PL2, 3): Allows display (setting) of only condition data protect levels.

4.6 A setting method of each parameter

4.6.1 Setting Condition Data

Condition data is a group of parameters for setting up basic actions such as a protect level, measurement range, and each control's operation type.

Measurement operation

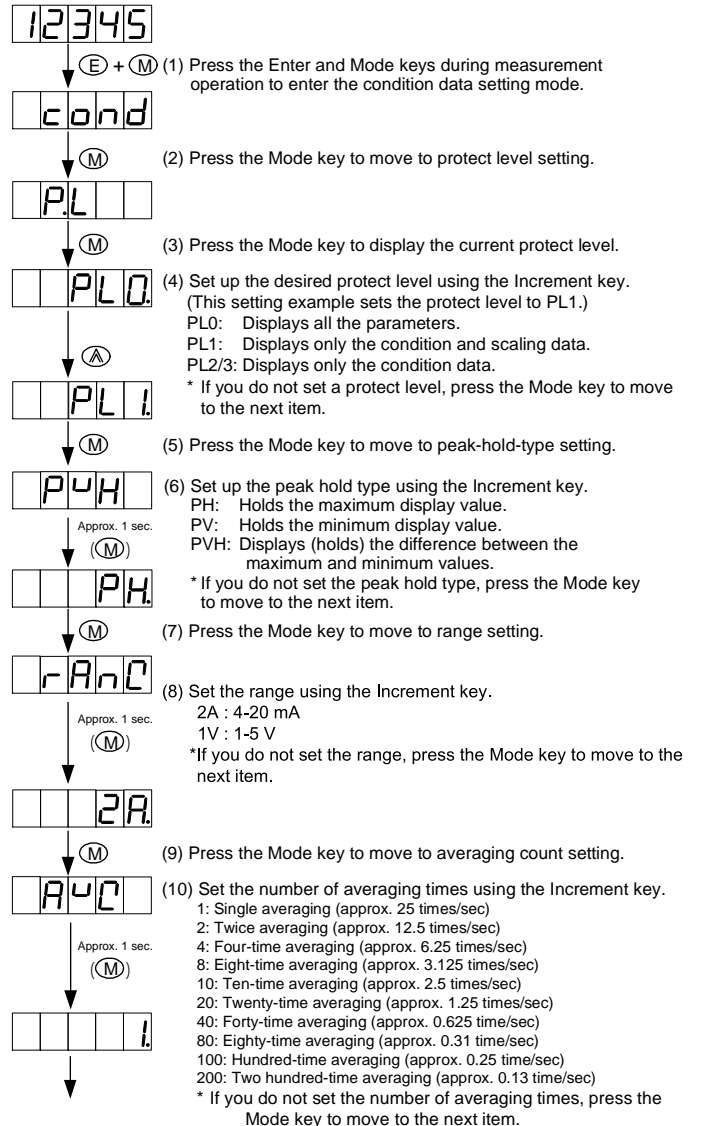

(11) Press the Mode key to move to moving averaging count setting.

(12) Set the number of moving averaging times using the Increment key.
 OFF: No moving averaging 8: Eight-time moving averaging
 2: Twice moving averaging 16: Sixteen-time moving averaging
 4: Four-time moving averaging 32: Thirty-two-time moving averaging
 * If you do not set the number of moving averaging times, press the Mode key to move to the next item.

(13) Press the Mode key to move to step-wise setting.

(14) Set up step-wise using the Increment key.
 1: Normal display
 2: Only even numbers in the least significant digit
 5: Only "0" or "5" in the least significant digit
 0: Only "0" in the least significant digit
 * If you do not set step-wise, press the Mode key to move to the next item.

(15) Press the Mode key to move to display blank setting.

(16) Set up display blank using the Increment key.
 OFF: Normal condition (brightest)
 b-3: Bright
 b-2: Slightly dim
 b-1: Dim
 ON: Off
 * If you do not set display blank, press the Mode key to move to the next item.

(17) Press the Mode key to move to digital limiter type setting.

(18) Set up digital limiter type using the Increment key.
 CUT: Holds display indication at a digital limiter value.
 OVER: Displays overrange if an input or display value exceeds the digital limiter range.
 * If you do not set the digital limiter type, press the Mode key to move to the next item.

(19) Press the Mode key to move to BCD output logic type setting. (This parameter is displayed only for the units with BCD outputs.)

(20) Set up the BCD output type using the Increment key.
 N.LOG: Negative logic Since, as for logic, Opencollector serves as a standard, TTL becomes reverse.
 P.LOG: Positive logic
 * If you do not set the BCD output type, press the Mode key to move to the next item.

(21) Press the Mode key to move to digital zero value backup setting.

(22) Set up digital zero backup using the Increment key.
 OFF: Discards a digital zero value when power is disconnected.
 ON: Stores a digital zero value when power is disconnected.
 * If you do not set digital zero backup, press the Mode key to move to the next item.
 Note that there is a limit on the number of writes available for the EEPROM.

(23) Press the Mode key to move to linearize function setting. (This parameter is displayed only when the protect level is at PL0.)

(24) Set up the linearize function using the Increment key.
 CLR: Initializes linearize data. OFF: Disables the linearize function.
 ON: Enables the linearize function.
 * If you do not set the linearize function, press the Mode key to move to the next item.

(25) Press the Mode key to move to tracking correction time setting.

(26) Set up tracking zero correction time using the Increment key.
 00 to 99: Set value x number of averaging (sampling) times
 * If you do not set tracking zero correction time, press the Mode key to move to the next item.

(27) Press the Mode key to move to tracking correction width setting. * This parameter is displayed only when tracking zero correction time is set.

(28) Set a tracking zero correction width using the Increment key.
 01 to 99: Set value x digit (numeric value)
 * This parameter can be set only when no tracking zero correction time is set.

(29) Press the Mode key to move to power-on delay setting.

(30) Set up power-on delay using the Increment key.
 01 to 30: Set value x seconds
 * If you do not set power-on delay, press the Mode key to move to the next item.

(31) Press the Enter key to return to measurement operation (if you press the Mode key, the panelmeter returns to the setting menu).

4.6.2 Setting Scaling Data

Scaling data is a group of parameters relating to measurements such as scaling or decimal points.

Measurement operation

12345

(1) Press the Enter and Mode keys during measurement operation to enter the condition data setting mode.

cond

(2) Press the Shift key to move to the scaling data setting mode.

NET

(3) Press the Mode key to display full-scale display value setting.

FSc

(4) Press the Mode key to enter the actual setup mode.

19999

(5) Set up a display value provided at full-scale input, using the Shift and Increment keys. (This setting example sets a full-scale display value to "18000.")
 ⏪ : Used to move to the setting digit (Shift key)
 ▲ : Used to set a numeric value (Increment key)
 * If you do not set a full-scale display value, press the Mode key to move to the next item.

18000

(6) Press the Mode key to display full-scale input-value setting.

FLn

(7) Set up a full-scale input value using the Shift and Increment keys.
 * If you do not set a full-scale input value, press the Mode key to move to the next item.

19999

(8) Press the Mode key to display offset display value setting.

oFS

(9) Set up a display value indicated at offset input using the Shift and Increment keys.
 * If you do not set an offset-input display value, press the Mode key to move to the next item.

. 0

(10) Press the Mode key to display offset input value setting.

oLn

(11) Set up an offset input value using the Shift and Increment keys.
 * If you do not set an offset input value, press the Mode key to move to the next item.

. 0

(12) Press the Mode key to display the digital limiter's high limit setting.

dLHc

(13) Set up the digital limiter's high limit using the Shift and Increment keys.
 * If you do not set the digital limiter's high limit, press the Mode key to move to the next item.

19999

(14) Press the Mode key to display the digital limiter's low limit setting.

dLLo

(15) Set up the digital limiter's low limit using the Shift and Increment keys.
 * If you do not set the digital limiter's low limit, press the Mode key to move to the next item.

.99999

(16) Press the Mode key to display decimal-point setting.

dEP

(17) Using the Shift key, set blinking the decimal point of the digit whose decimal point you wish to light up. (If the decimal point is not blinking, there is no decimal point.)
 * If you do not carry out a setting, press the Mode key to move to the next item.

. . . .

(18) Press the Enter key to return to measurement operation (if the Mode key is pressed, the panelmeter returns to the Setup menu).

12345

Example of setting scaling data:

Example of setting 1

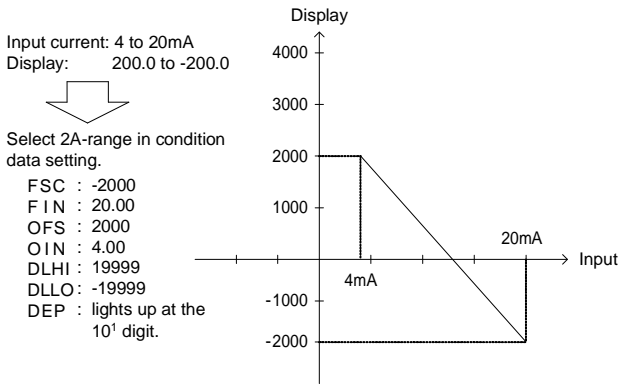

Example of setting 2

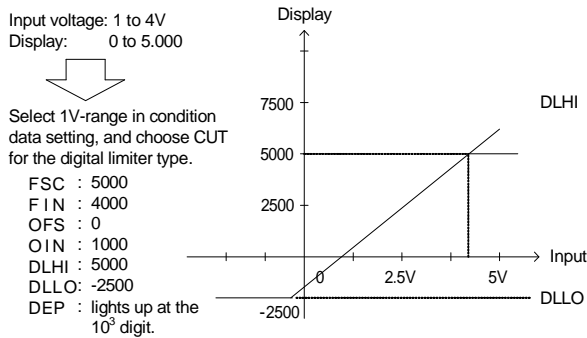

* Digital Limit Function

The digital limit function is a function for controlling display indication by concurrent use of digital limiter-type setting in the condition data and a digital limit set value in the scaling data. If CUT is selected for the digital limiter type in the condition data, the display value is held at the limit value set in the scaling data as shown in example of setting 2 above. Moreover, selection of OVER for the digital limiter type causes "o.L." to appear if an input is made that results in exceeding the limit value set in the scaling data.

4.6.3 Setting Linearize Data

Linearize data is a group of parameters relating to the function of correcting the linearity between input and display values. The linearize function corrects the linear relationship between input and display values at any point to change the inclination of the linearity. Linearize data is set using an input value (display value before correction) and output value (display value after correction) at any point. To use the linearize function, carry out this linearize data setup first and then set the linearize function for activation in the condition data. The linearize function works only after that.

Measurement operation

12345

cond

LnE

n-0.0

1.0

n-0.1

.0 RE

.0 DZ

n-0.2

23456

- Press the Enter and Mode keys during measurement operation to enter the condition data setting mode.
- Press the Shift key twice to move to the linearize data setting mode.
- Press the Mode key to display linearize point count setting.
- Set the number of linearize points using the Shift and Increment keys. (This setting example sets the number of linearize points to "10.")
 ⏪ : Used to move to the setting digit (Shift key)
 ▲ : Used to set a numeric value (Increment key)
 * You must set the number of linearize points; otherwise you cannot move to the next item. To exit linearize setting, press the Mode key.
- Press the Mode key to display a linearize point.
- Press the Mode key to display input value setting with respect to the linearize point selected. "RE" LED also blinks during setting of an input value.
 * The input value is a display value for an input before executing linearization.
- Press the Mode key to display output value setting with respect to the linearize point. "DZ" LED also blinks during setting of an output value.
 * The output value is a display value for the input made after execution of linearization.
- Press the Enter key to return to measurement operations.
 * After completion of setting, carry out linearize function setup in the condition data to activate this function for use.

* The setting conditions are $N - 1 < N - 2 \dots N - 15 < N - 16$, and if these conditions are not met, "Err" appears. If this happens, carry out the setting again. The number of linearize points is up to 16, but a value "17 to 19" is also displayed during setup. Note that if you set a value from 17 to 19, it is forced to set it to "16."

5. Other Functions

5.1 Display Shift Function

The display shift function is a function for arbitrarily shifting only the indication without changing the inclination of an input signal.

Measurement operation

12345

SHF

.0

-0345.

120.00

12000

- Press the Enter and Mode keys during measurement operation to enter the display shift setting mode.
- The panelmeter enters the shift numeric setting mode.
- Set the number of digits by which you wish to shift the display indication, using the Shift and Increment keys. (This setting example sets a full-scale display value to "-345.")
 ⏪ : Used to move to the digit where you carry out the setting (Shift key)
 ▲ : Used to set a numeric value (Increment key)
 * The polarity is switched by incrementing the most significant digit.
- Check the computation results using the Mode key. In this case, the decimal points of the 10² digits and 10³ digits blink.
- Press the Enter key to return to measurement operation.
 * To clear the display shift function, set "0."

5.2 Monitoring Mode

The A8000 series can display the maximum value, minimum value, the difference between them (maximum value - minimum value), and input values in the main display. Pressing the Increment key with the Enter key held down causes the panelmeter to enter the display status in each mode. To switch to each mode, press the Shift key for approximately one second. This switches the display value in the order of the maximum value, minimum value, and the difference (maximum value - minimum value), and the input value. Moreover, pressing the Increment key for

approximately one second allows you to clear the display value. Press the Enter key to return to the normal indication. (The next time you enter the monitoring mode, the mode you were in when you exited on the previous occasion is activated.)

Maximum value: The maximum value is displayed, blinking the decimal point of the 10⁴ digit.

Minimum value: The minimum value is displayed, blinking the decimal point of the 10⁰ digit.

Maximum value – minimum value: The difference between the maximum and minimum values is displayed, blinking the decimal points of the 10⁰ and 10⁴ digits. If a display value exceeds the displayable range, the indication of the 10³ digit becomes \square , lighting up its decimal point.

Input value: The input value is displayed, blinking the decimal points of the 10⁰ and 10¹ digits.

5.3 Tracking Zero

The tracking zero is a function for automatically digitally correcting the movement of the zero point inside. This function starts to work at the instant the digital zero function is enabled. Correction is made according to the values set for the tracking zero time setting and tracking zero width setting in the condition data.

Example of setting: Tracking zero time setting 5 (correction made every averaging (sampling))
Tracking zero width setting 3 (correction width of 3 digits)

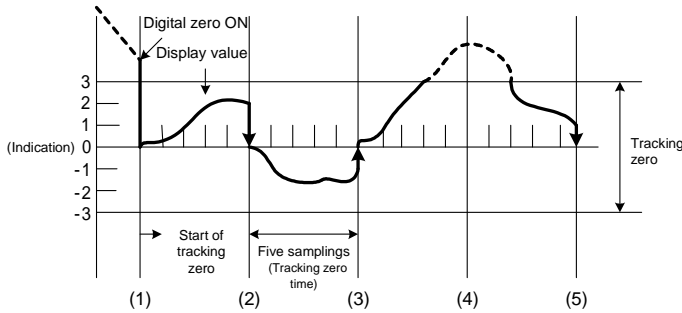

- (1): Indication of the digital zero function is zero.
- (2)(3): Because the indication at the 5th sampling is 3 digits or below, correction is made to display zero.
- (4): No correction is made because the display value is out of the correction range.
- (5): Correction is made to display zero because the display value is three digits or less.

6. External Control Function

For those equipped with BCD outputs, there are the hold, digital zero (terminal control), and peak hold functions that can be external controlled.

The external control terminals are DC isolated from the power and input terminals.

6.1 Hold Function

The hold function is a function for stopping indication at an arbitrary timing. It is activated by shorting the HOLD and D.COM terminals or bringing their potential to the "0" level.

6.2 Digital Zero Function

The digital zero function is a function for resetting indication to zero at an arbitrary timing and then displaying a range of variations from that point onward. ON/OFF of the digital zero function can be controlled either by the terminal control or by using keys on the front panel.

For terminal control, this function is activated by shorting the DZ and D.COM terminals or bringing the potentials of them to the "0" level.

For control using front-panel keys, it can be activated by pressing the Increment key with the Mode key held down. Taking the same step again causes this function to be deactivated.

For operation using the control terminals or the front panel keys, terminal control has precedence over front-panel key operation.

6.3 Peak Hold Function

The peak hold function is a function for holding the maximum value (Peak Hold), the minimum value (Valley Hold), and the difference between them (Peak Valley Hold). Switching between these holding functions is achieved using condition data. The peak hold function is activated by shorting the P/H and D.COM terminals or bringing their potential to the "0" level.

6.4 Control Terminal Levels

The levels of each control terminal are as shown below:

"0" level: 0 to 1.5 V

"1" level: 3.5 to 5 V

Input current: -0.5 mA

7. Specifications

Input Specifications

Process signal measurements

Range	Measurement Range	Disply	Accuracy	Input Impedance	Maximum Permissible Input
1V	1~5V	Offset 19999	±(0.1% of rdg + 3digit)	約1M	±50V
2A	4~20mA	Full scale 19999	±(0.2% of rdg + 3digit)	約10	±50mA

Decimal point : By the front sheet switch, a setup is arbitrarily possible.

(Please refer to 4.6.2 (16)(17)for details.)

Common Specifications

- Input circuit: Single-ended type
- Operation system: $\Delta\Sigma$ conversion method
- Display: 7-segment LED, red, character height of approx. 10 mm
- Sampling rate: 25 times/sec maximum
- Display range: -19999 to 19999
- Overrange warning: "o.L" or "-o.L" indication with respect to an input signal exceeding the display range
- Zero indication: Leading zero suppression
- Operating temperature and humidity ranges: 0 to 50°C, 35 to 85% R.H (no condensation)
- Storage temperature and humidity ranges: -10 to 70°C, 60% R.H or less (no condensation)
- External dimensions: 48 mm (W) x 24 mm (H) x 89.1mm (D) (when equipped with BCD outputs)
- Weight: Approx. 70g
- Dielectric strength: 500 V DC for one minute between the power terminal and each of the input, BCD output, and external control terminals
500 V DC for one minute between the input terminal and each of the BCD output and external control terminals
1500 V AC for one minute between the casing and each terminal
- Insulation resistance: 100 M Ω or more at 500 V DC between the above-noted terminals

Power Specifications

- Supply voltage range: 4.75 to 13.2 V DC
10.8 to 26.4 V DC
- Power consumption: approx. 2 W

Option Specifications

BCD Outputs

TTL output

- Measured data: Tri-state parallel BCD
- Polarity signal: 1 level for negative indication
- Overrange signal: 1 level for overrange indication
- Printout command signal: Positive pulse output after the completion of measurement
- Output logic: Switchable (PC logic not switchable)
- Output signal: TTL level fan-out = 2, COMS compatible

Open collector output (NPN type)

- Measured data: Transistor ON when negative logic is logic 1
- Polarity signal: Transistor ON for negative indication
- Overrange signal: Transistor ON for overrange indication
- Printout command signal: Transistor ON after the completion of measurement
- Output logic: Switchable (PC logic not switchable)
- Transistor output capacity: Voltage 30 V DC max., Current 10 mA max.
Output saturation voltage 1.2 V or less at 10 mA

Enable

- Enable input: Shorting the ENABLE and D.COM terminals or bringing their potential to the "0" level causes BCD output to be high impedance (TTL) or the transistor to be turned OFF.
- Control signal "0" level: 0 to 1.5 V with respect to the D.COM terminal
- Control signal "1" level: 3.5 to 5 V with respect to the D.COM terminal

External Control

- Hold: The hold function is activated by shorting the HOLD and D.COM terminals or bringing the potentials of them to the "0" level.
- Digital zero: The digital zero function is activated by shorting the DZ and D.COM terminals or bringing their potential to the "0" level.
- Peak hold: The peak hold function is activated by shorting the PH and D.COM terminals or bringing their potential to the "0" level.
- Control signal "0" level: 0 to 1.5 V with respect to the D.COM terminal
- Control signal "1" level: 3.5 to 5 V with respect to the D.COM terminal

8. List of the Parameters

8.1 Condition Data

Mene	Parameter	Initial (*)	PL	Selections/ Ranges	Function/Remarks
PL (P.L)	Protect level	PL0	PL2	PL0/PL1 PL2/PL3	Selects the protect level for preventing incorrect operation. The higher the protect level, the more limitations are imposed on a set parameter.
PVH (PVH)	PH select	PH	PL0	PH/VH/PVH	Selects the type (peak hold, valley hold, or peak-valley hold) that is activated when the PH function is enabled.
RANG (RANG)	Input range	2R	PL1	2R/1V	Selects the input range.
AVG (AVG)	Average rate	1	PL1	1/2/4/8/10/20 40/80/100/200	Selects the number of averaging times (sampling). Sampling rate is set as the number of averaging times of 25/sec (40 ms). This is the actual sampling time.
MAV (MAV)	Moving average rate	OFF	PL0	OFF/2/4 8/16/32	Selects the number of moving averaging times. (Smaller filtering effect OFF 2 4 8 16 32 Larger filtering effect)
S.WD (S.WD)	Step-wide	1	PL0	1/2/5/0	Sets the resolution of the least significant digit. (When it is set to "5", the least significant digit indicates only "0" or "5".)
BLNK (BLNK)	Display blank level	OFF	PL0	OFF/b-3/b-2 b-1/on	Selects display brightness. (Bright OFF b-3 b-2 b-1 ON Extinguished)
DLT (DLT)	Digital limiter type	CUT	PL0	CUT/OVER	Sets the displayable range type. When CUT is selected, the set value is displayed; when OVER is selected, "o.L." is displayed.
BCD.L (BCD.L)	BCD output logic	nLoL	PL0	nLoL/PLoL	Selects the BCD output logic (N: negative logic, P: positive logic). * Only when BCD outputs are provided
D.VP (D.VP)	DZ backup	OFF	PL0	OFF/on	Selects whether to backup the digital zero value when power is disconnected.
LINE (LINE)	Linearization	CLR	PL0	CLR/OFF/on	Selects the enable (ON) /disable (OFF) of the linearize function and data clara (CLR).
TR.T (TR.T)	Tracking zero correction time	00	PL0	00 - 99	Sets the enable/disable of the tracking zero function and correction time (setpoint/conversion rate).
TR.W (TR.W)	Tracking zero correction width	01	PL0	01 - 99	Sets the correction width of the tracking zero function. * Only when TR.T is a value other than 00.
PON (PON)	Power-on delay time	OFF	PL0	OFF - 30	Sets the time (setpoint x 1 sec.) taken from when the power is turned on to the instant when measurement is actually started.

* In case of No switch display option, parameters are set specified values, protect level is "PL3".

8.2 Scaling Data

Mene	Parameter	Initial (*)	PL	Selections/ Ranges	Function/Remarks
FSC (FSC)	Full-scale display value	19999	PL1	-19999 - 19999	Sets the relationship between an input signal and display value. 1V range initial is in a parenthesis.
FIN (FIN)	Full-scale input value	2000 (5000)	PL1	-2000 - 2000 (-5000 - 5000)	
OFS (OFS)	Offset display value	0	PL1	-19999 - 19999	
OIN (OIN)	Offset input value	400 (1000)	PL1	-2000 - 2000 (-5000 - 5000)	
DLHI (DLHI)	Digital limiter HI	19999	PL0	-19999 - 19999	Sets the high limit of the displayable range. (If a value exceeding the digital limiter HI setpoint is input, the display value is not updated, but is held at the set value.)
DLLO (DLLO)	Digital limiter LO	-19999	PL0	-19999 - 19999	Sets the high limit of the displayable range. (If a value below the digital limiter LO setpoint is input, the display value is not updated, but is held at the set value.)
DP (DP)	Decimal point	...	PL1	Arbitrarily settable at each digit	Sets the decimal-point display position.

* In case of No switch display option, parameters are set specified values, protect level is "PL3".

9. Error Messages

Error Display	Description	How to Recover or Remedy
	An input value or display value has exceeded the measurement range.	Use the panelmeter within the specified measurement and display ranges.
	Microcomputer is waiting for data to be input.	Check if the number of averaging times is set to an appropriate value.
	Meter's internal memory failure	Turn power on again. If it does not recover from the failure, contact your sales representative or our sales office directly.
	Condition data error	Carry out condition data setting again. * Modify one or more data and go through the parameters once.
	Scaling data error	Carry out scaling data setting again. * Modify one or more data and go through the parameters once.
	Linearize data error	Carry out linearize data setting again. * Modify one or more data and go through the parameters once.
	Shift data error	Carry out shift data setting again.
	Digital zero value backup data error	Write the digital zero value.

* Turning the power on with all the front-panel keys (Enter, Mode, Shift, and Increment) held down, allows you to reset all the parameters to the defaults.

10. Timing Chart

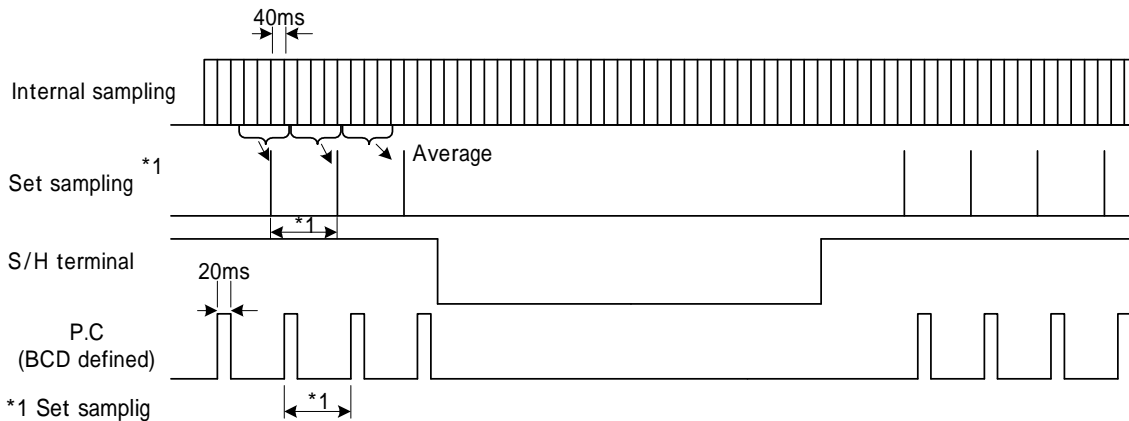

*1 Set samplig

A value set using the AVG parameter in the condition data becomes the practical sampling rate of the A8000 series.

Set AVG Counts	Set Sampling Rate	Set Sampling Period	Set AVG Counts	Set Sampling Rate	Set Sampling Period
1	25times/sec	40ms	20	1.25 times/sec	800ms
2	12.5 times/sec	80ms	40	0.625 times/sec	1.6s
4	6.25 times/sec	160mS	80	0.3125 times/sec	3.2s
8	3.125 times/sec	320ms	100	0.25 times/sec	4s
10	2.5 times/sec	400ms	200	0.125 times/sec	8s

11 Warranty and After Sales Service

11.1 Warranty

The manufacturer warrants to the original retail customer its 46AC series universal digital panel meter to be free of defects in material and workmanship for use under normal care and will repair or replace any meter at no charge to the customer during the one (1) year warranty period of the meter.

11.2 After Sales Service

Under strict quality control measures, this product was manufactured, tested, inspected and shipped. Should a defect in manufacture or Workmanship be identified, please return the product to our distributor or directly to us. It would be highly appreciated if you could give a detailed account of the fault and enclose it with the product.

watanabe

WATANABE ELECTRIC INDUSTRY CO., LTD.

6-16-19, Jingumae, Shibuya-ku, Tokyo 150-0001, Japan

Phone: (81)3-3400-6141

Homepage <http://en.watanabe-electric.co.jp/>