

NI15-EM30-AP6/S907

Inductive sensor – With extended temperature range

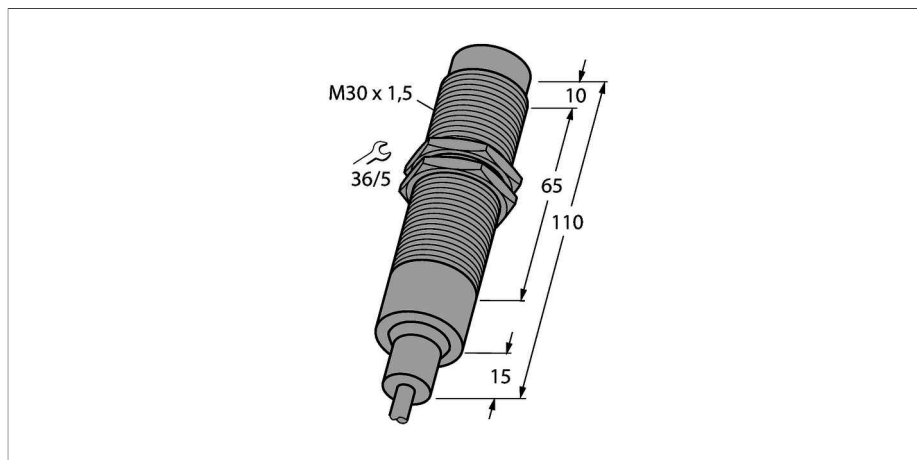

Features

- Threaded barrel, M30 x 1.5
- Stainless steel, 1.4571
- Temperatures up to +160 °C
- DC 3-wire, 10...30 VDC
- NO contact, PNP output
- Cable connection

Wiring diagram

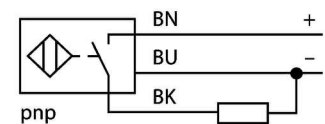

Technical data

Type	NI15-EM30-AP6/S907
ID number	4617412
Rated switching distance	15 mm
Mounting conditions	Non-flush
Secured operating distance	≤ (0,81 x S _n) mm
Correction factors	St37 = 1; Al = 0.3; stainless steel = 0.7; Ms = 0.4
Repeat accuracy	≤ 2 % of full scale
Temperature drift	≤ ± 20 %
Hysteresis	3...15 %
Ambient temperature	-25...+160 °C
Operating voltage	10...30 VDC
Residual ripple	≤ 10 % U _{ss}
DC rated operational current	≤ 200 mA
Rated operational current	See derating curve
No-load current	≤ 15 mA
Residual current	≤ 0.1 mA
Isolation test voltage	≤ 0.5 kV
Short-circuit protection	yes / Cyclic
Voltage drop at	≤ 1.8 V
Wire breakage/Reverse polarity protection	yes / Complete
Output function	3-wire, NO contact, PNP
Switching frequency	0.2 kHz
Design	Threaded barrel, M30 × 1.5
Dimensions	110 mm
Housing material	Stainless steel, V4A (1.4571)
Active area material	Plastic, PEEK
End cap	Plastic, PTFE

Functional principle

Inductive sensors detect metal objects contactless and wear-free. For this purpose they use a high-frequency electromagnetic AC field that interacts with the target. The sensors hosting a ferrite core coil generate the AC field through an LC resonant circuit. Special versions are available for ambient temperatures between -60°C and +250°C.

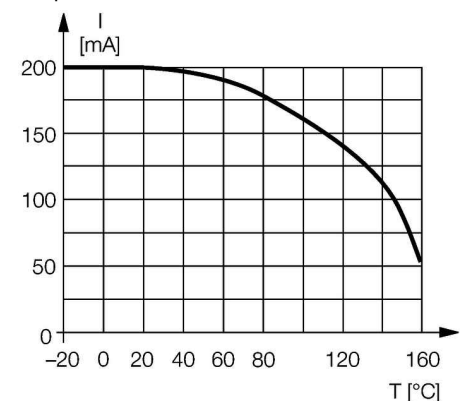

Technical data

Max. tightening torque housing nut	75 Nm
Electrical connection	Cable
Cable quality	Ø 3.7 mm, PTFE, FEP, 2 m
Cable cross section	3 x 0.34 mm ²
Vibration resistance	55 Hz (1 mm)
Shock resistance	30 g (11 ms)
Protection class	IP68/IP69K

Mounting instructions/Description

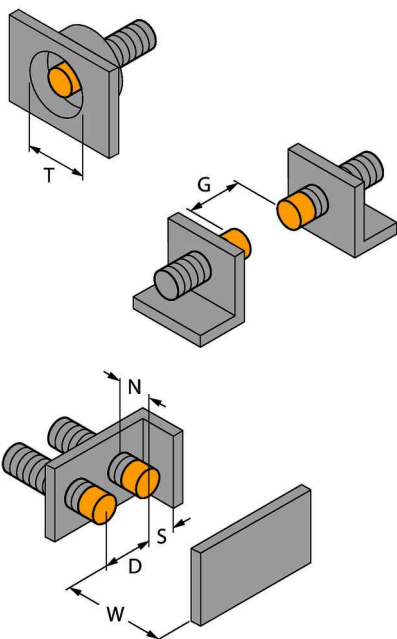

Distance D	3 x B
Distance W	3 x Sn
Distance T	3 x B
Distance S	1.5 x B
Distance G	6 x Sn
Distance N	2 x Sn
Diameter active area B	Ø 30 mm

Mounting accessories

MW-30 6945005

Mounting bracket for threaded barrel devices; material: Stainless steel A2 1.4301 (AISI 304)

